

Fast door

RIPO TermoSpeed

Dimensions and installation requirements



Two types of tracks available:

A) Spiral wind-up system



B) Standard track system



Fast door **RIPO TermoSpeed**

A) Spiral wind-up system



Dimensions and installation requirements

Right side drive

Dimensions

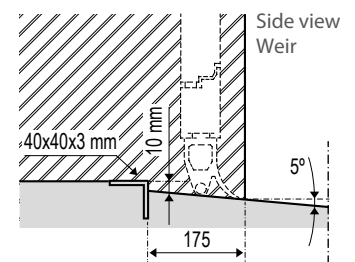
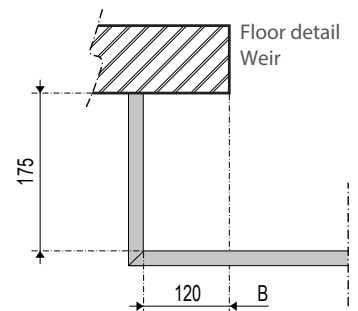
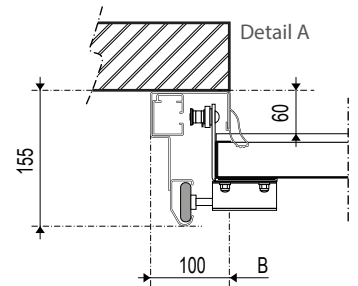
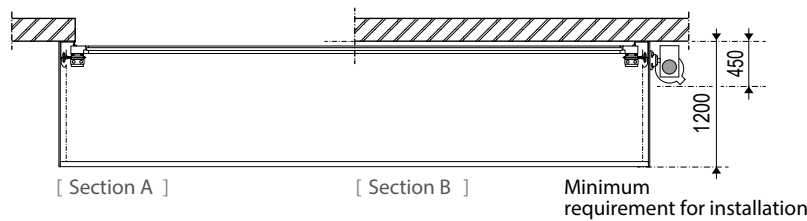
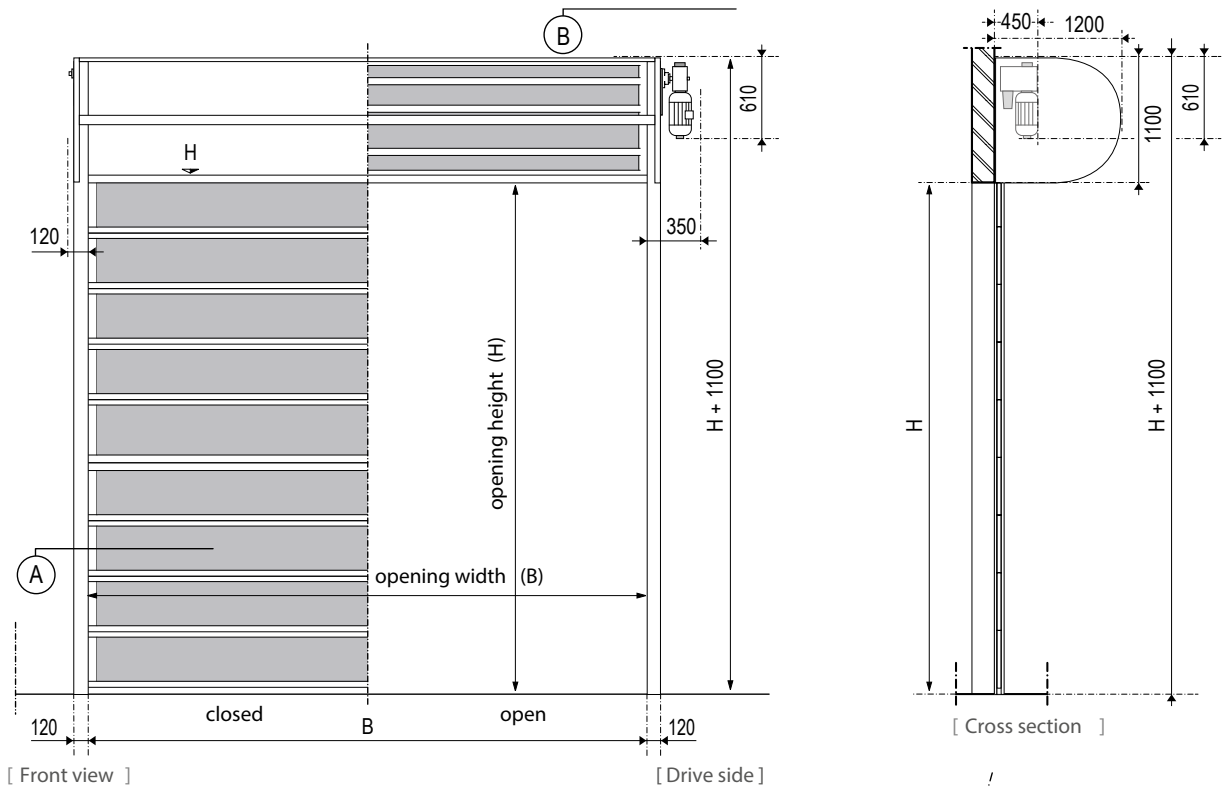

Installation requirements

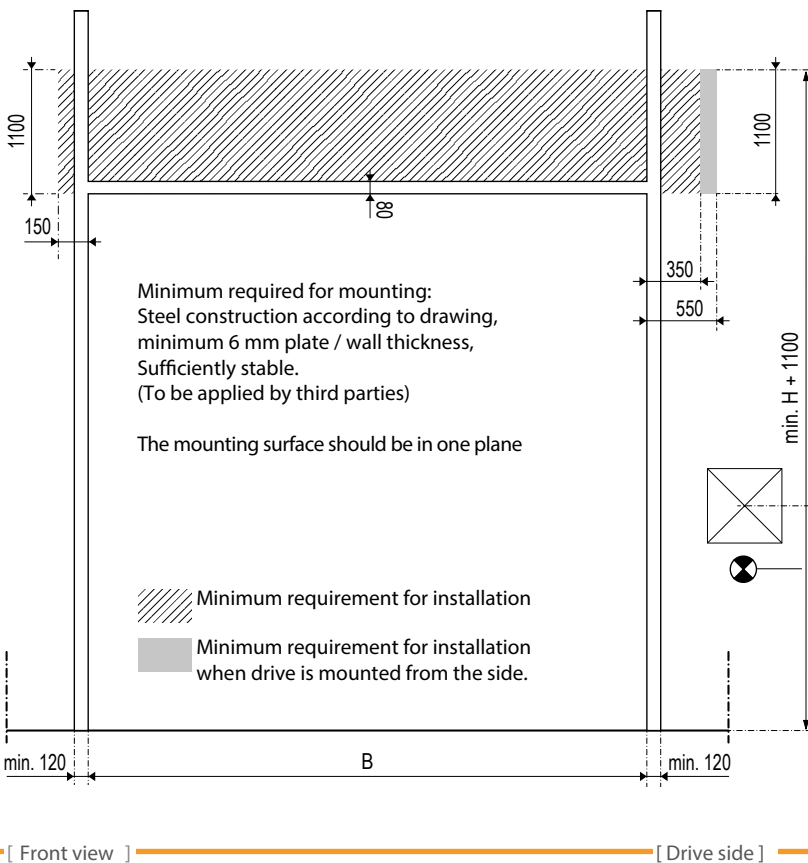

- CEE-form 3~N PE 400V/50Hz/16A
- Electrical supply by others
- Control box/ power supply, inside RIGHT
- Control box/ power supply, inside LEFT

[Cross section]

Fast door **RIPO TermoSpeed**

B) Standard track system



Dimensions and installation requirements

Right side drive

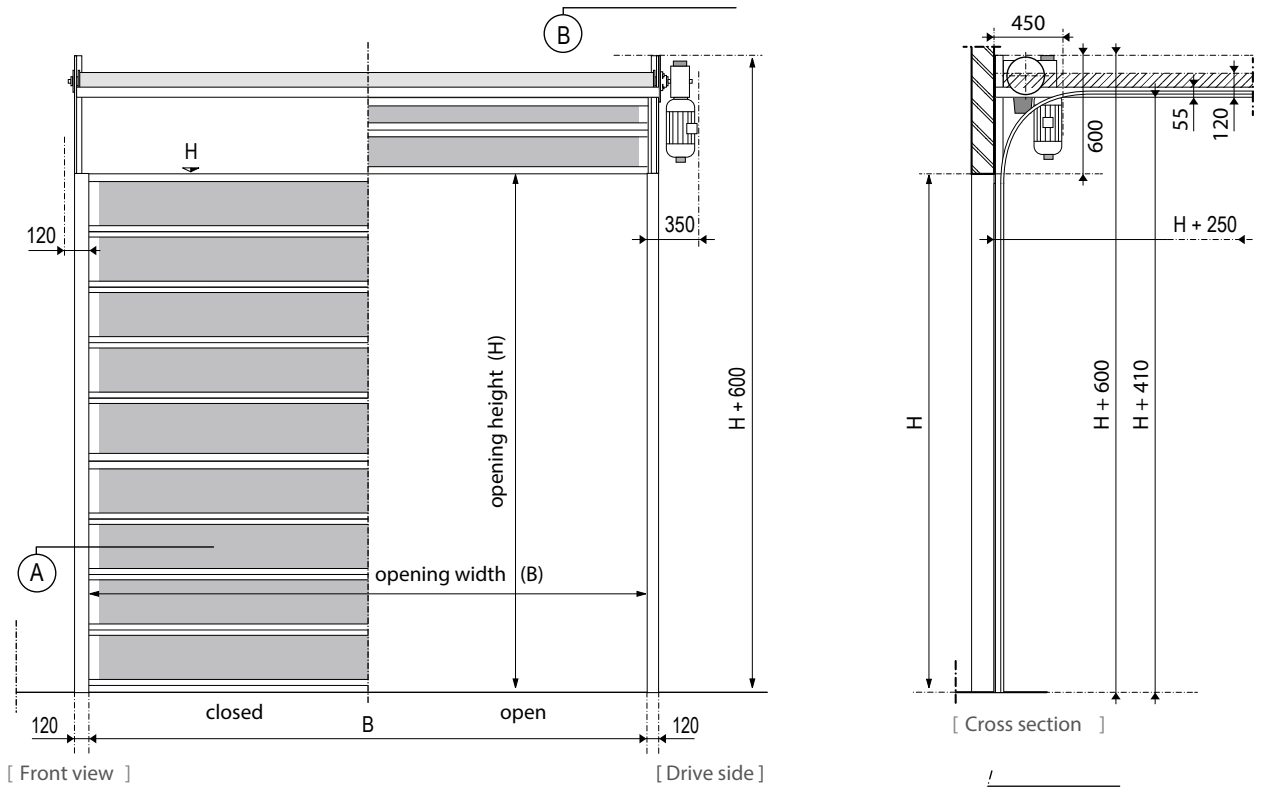

Dimensions

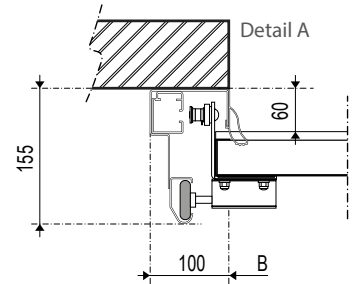
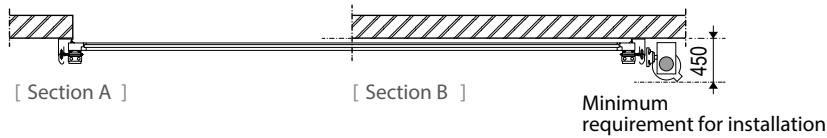

Installation requirements

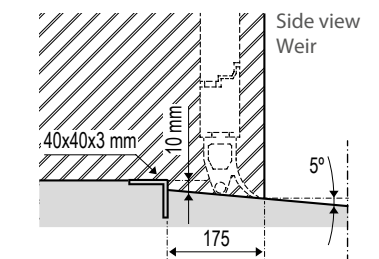
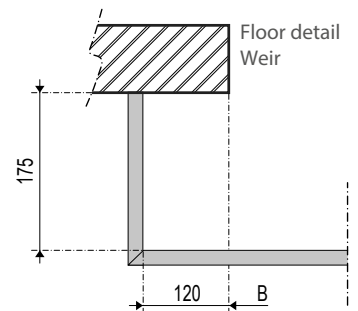
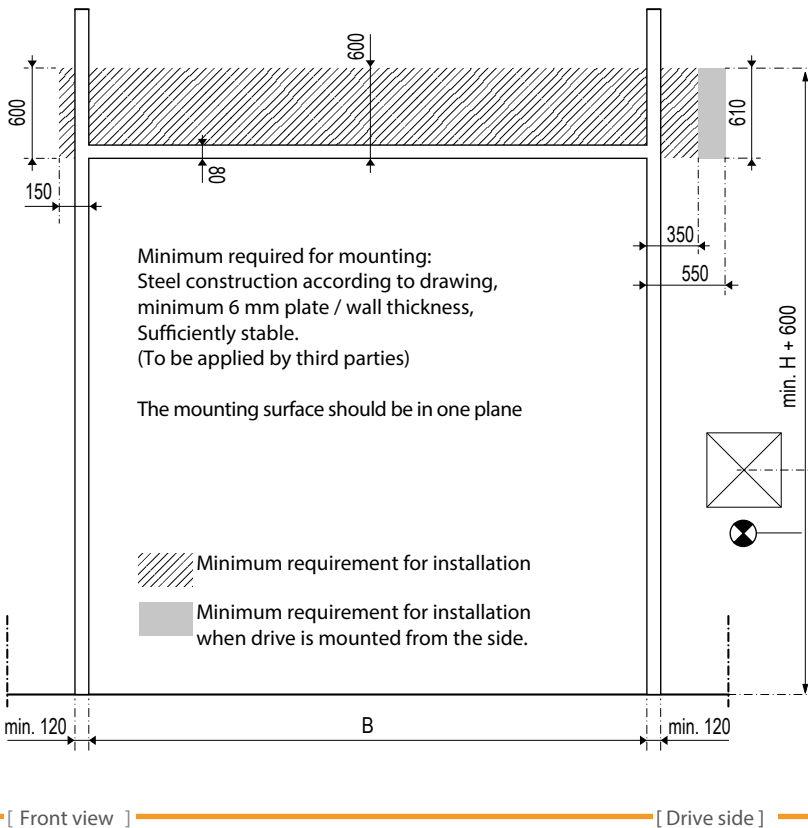

- CEE-form 3~N PE 400V/50Hz/16A
- Electrical supply by others
- Control box/ power supply, inside RIGHT
- Control box/ power supply, inside LEFT